

REGULATION VALVES**TYPE:****MED-01...-06-01,-11,-02,-12****MEO-01...-06-01,-11,-02,-12****MEZ-01...-06-01,-11,-02,-12**

	TECHNICAL PRODUCT DOCUMENTATION	ME5-0103
		Page: 2 Pages: 16

CONTENTS

1. INTRODUCTION	3
1.1. SECURITY INSTRUCTIONS	3
1.1.1. Application	3
1.1.2. Definitions used in description	3
1.1.3. Allowed activities range	3
1.1.4. Instructions and warnings	3
1.2. SUBJECT OF TECHNICAL PRODUCT DOCUMENTATION	4
1.3. APPLICATION, MARKINGS ACC. TO SWW AND PKWiU	4
1.4. CONSTRUCTION AND WORKING RULES	4
2. TECHNICAL DATA	10
3. ORDERING METHOD AND EXAMPLE OF ORDERING	11
4. MAINTENANCE INSTRUCTION	12
4.1. ASSEMBLY INSTRUCTION	12
4.2. STARTING AND SERVICE INSTRUCTION	15
4.2.1. Preparing products for starting	15
4.2.2. Maintenance instruction	15
4.3. CONSERVATION INSTRUCTION	15
4.4. INDUSTRIAL SAFETY INSTRUCTION	15
5. STORAGE AND TRANSPORT TERMS	15
6. SETS DELIVERY	16
7. GUARANTY TERMS	16
8. DECLARATION	16

	TECHNICAL PRODUCT DOCUMENTATION	ME5-0103
		Page: 3 Pages: 16

1. INTRODUCTION

1.1 SECURITY INSTRUCTIONS

1.1.1 Application

The regulating valves of all the types and diameters are mainly designed for cooperation with Liquid-sealed Temperature Sensors HCT-.

The three-way regulating valve type MED- connected with temperature sensor type HCT- forms the temperature regulator of direct continuous action HCT- + MED-. The opening regulating valve type MEO- connected with temperature sensor type HCT- forms the temperature regulator of direct continuous action HCT- + MEO-

The closing regulating valve type MEZ- connected with temperature sensor type HCT- forms the temperature regulator of direct continuous action HCT- +MEZ-

Other applications should be consulted with manufacturer.

Manufacturer doesn't bear responsibility for any damages which result from using level switches in method not acct. to application. Risk is on user side.

Right using of level switches is make everything according to this document instructions.

1.1.2. Definitions used in description

- **Operator** – person, who use product according to application (PN-EN 61010-1, July 2004),
- **Technical inspection** - person or group of people responsible for using and conservation of product, this person has to assure of well special training for OPERATORS (PN-EN 61010-1, July 2004),

1.1.3. Allowed activities range



- **For operator** – valves using.
- **For technical inspections** – activities like for operator, mechanical and electrical assembly and activities connected with controlling.

1.1.4 Instructions and warnings

Body damage and/or serious material damages might be formed if user doesn't keep of instructions and warnings. Servicing staff have to be instructed and acquaint with whole safety instructions and warnings.

For well and safe regulation valves working there has to be assured right transport, storage, assembly, starting and conservation's instruction.

Main attentions of safety in mentioned operation and maintenance manual were marked as pictograms:

	<p>This sign means: Pointer.</p> <p>„Pointer” indicates on action or any process important for well-working of product. Material damages might be formed if user doesn't keep of instructions.</p>
	<p>This sign means: Warning.</p> <p>„Warning ” indicates on action or any process, which might be danger for staff or makes material damages if those aren't made correctly.</p>

	TECHNICAL PRODUCT DOCUMENTATION	ME5-0103
		Page: 4 Pages: 16

1.2. SUBJECT OF TECHNICAL PRODUCT DOCUMENTATION

“Technical product documentation” subject is parameters, conditions and instructions connected with construction of valves, assembling, transport, storing and using of valves.

1.3 APPLICATION, MARKINGS ACC. TO SWW AND PKWiU

Regulating valves are designed for regulation of flowing liquid and steam in many branches of industry, e.g.: chemical industry, heat and power engineering.

Marking acc. to Polish Classification of Products and Services (PKWiU): 28.14.13.0

Marking acc. to Systematic Products Specification (SWW) : -0919-2

1.4 CONSTRUCTION AND WORKING RULES

1.4.1. Construction of regulating valves (drawing no. 1 and 2):

- Valve body with seat - 1
- Seat body - 2
- Gland body - 3
- Sealing bellows - 4
- Stem - 5
- Plug - 6
- Unloading bellows - 7
- Return spring - 8
- Manual drive nut - 9
- Cover - 10

1.4.2. Working rules

Regulating valves are loaded, except the Dn15 size.

Regulating valves are designed for cooperation with liquid-sealed temperature sensors. When the valve is connected with temperature sensor, its action consists in:

- three-way valve at temperature increase – flow increase through the main passage, with simultaneous decrease through the side way.
- opening valve at temperature increase – flow increase through the seat.
- closing valve at temperature increase – flow decrease through the seat.

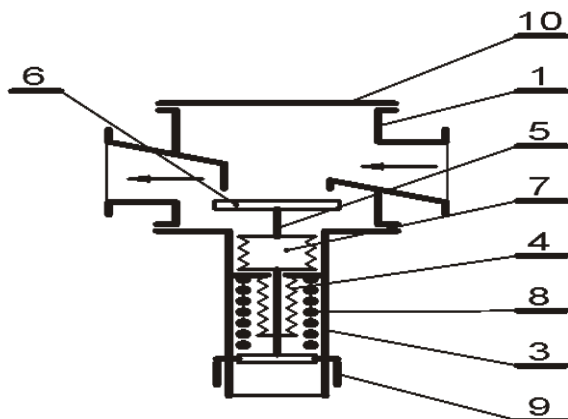
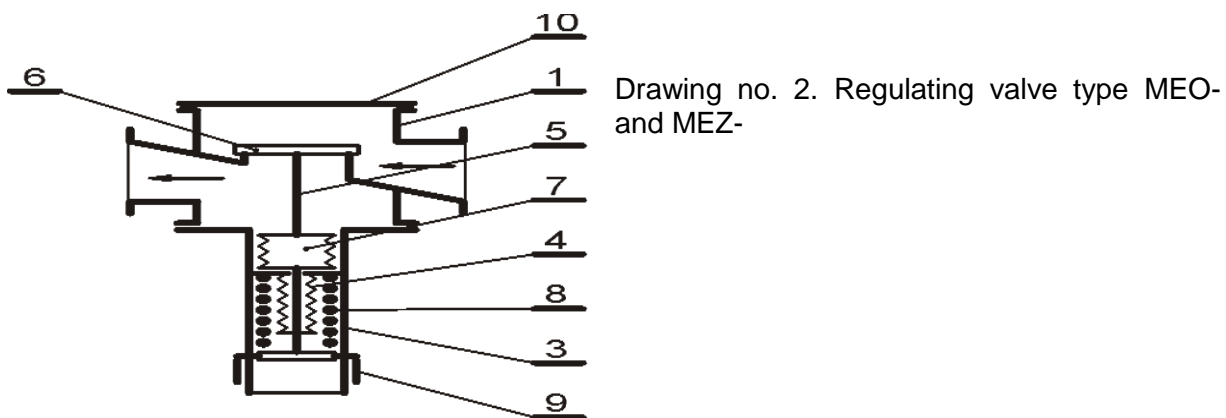
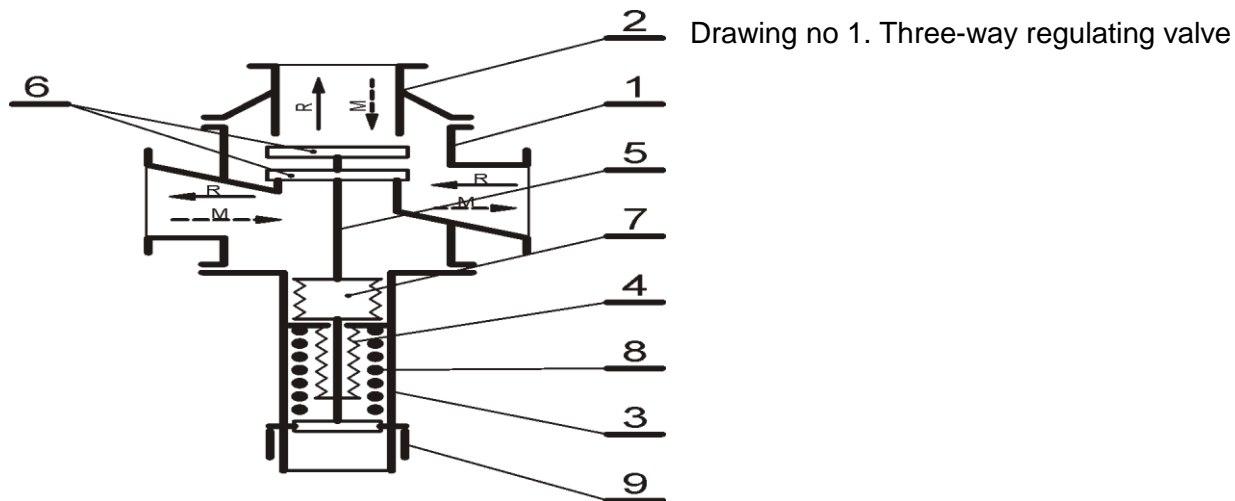

1.4.3 Dimensions

1.4.3.1. Three-way valve for cooperation with HCT sensor

Table no. 1

Valve's type	Dimension in mm							Valve's travel
	D_n	D_p	D_k	d_o	L	H	h	mm
MED-01-01*...02**	15	65	95	14	130	120	118	3
MED-02-01...02	20	75	105	14	150	140	129	4
MED-03-01...02	25	85	115	17	160	145	129	5
MED-04-01...02	32	100	140	18	180	150	148	6
MED-05-01...02	40	110	150	18	200	155	148	6
MED-06-01...02	50	125	165	18	230	205	167	9

The leakage measuring for water at $D_p = 0,2\text{MPa}$ * - hard valve seat ** - soft valve seat

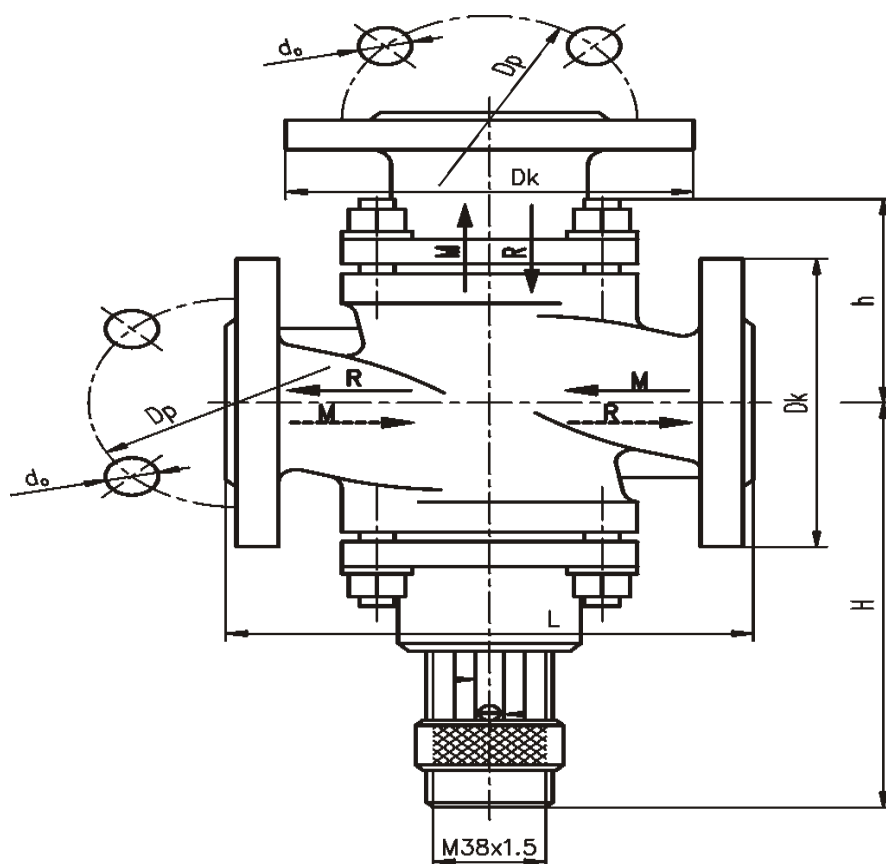

1.4.3.2. Regulating valves (opening and closing) for cooperation with HCT sensor

Table no. 2

Valve's type	Dimension in mm							Valve's travel mm
	D _n	D _p	D _k	d _o	L	H	h	
MEO-01-01*...02** MEZ-01-01...02	15 15	65 65	95 95	14 14	130 130	120 120	118 118	3
MEO-02-01...02 MEZ-02-01...02	20 20	75 75	105 105	14 14	150 150	140 140	129 129	4
MEO-03-01...02 MEZ-03-01...02	25 25	85 85	115 115	17 17	160 160	145 145	129 129	5
MEO-04-01...02 MEZ-04-01...02	32 32	100 100	140 140	18 18	180 180	150 150	148 148	6
MEO-05-01...02 MEZ-05-01...02	40 40	110 110	150 150	18 18	200 200	155 155	148 148	6
MEO-06-01...02 MEZ-06-01...02	50 50	125 125	165 165	18 18	230 230	205 205	167 167	9

The leakage measuring for water at D_p = 0,2MPa * - hard valve seat ** - soft valve seat

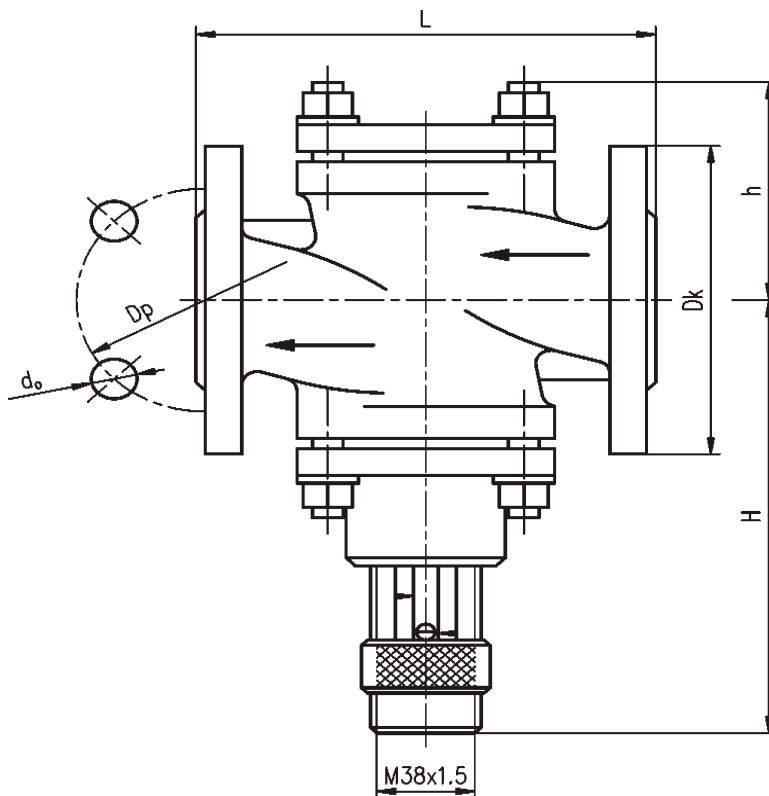

1.4.3.3. Three-way valve type MED for building of ESL-16 actuator

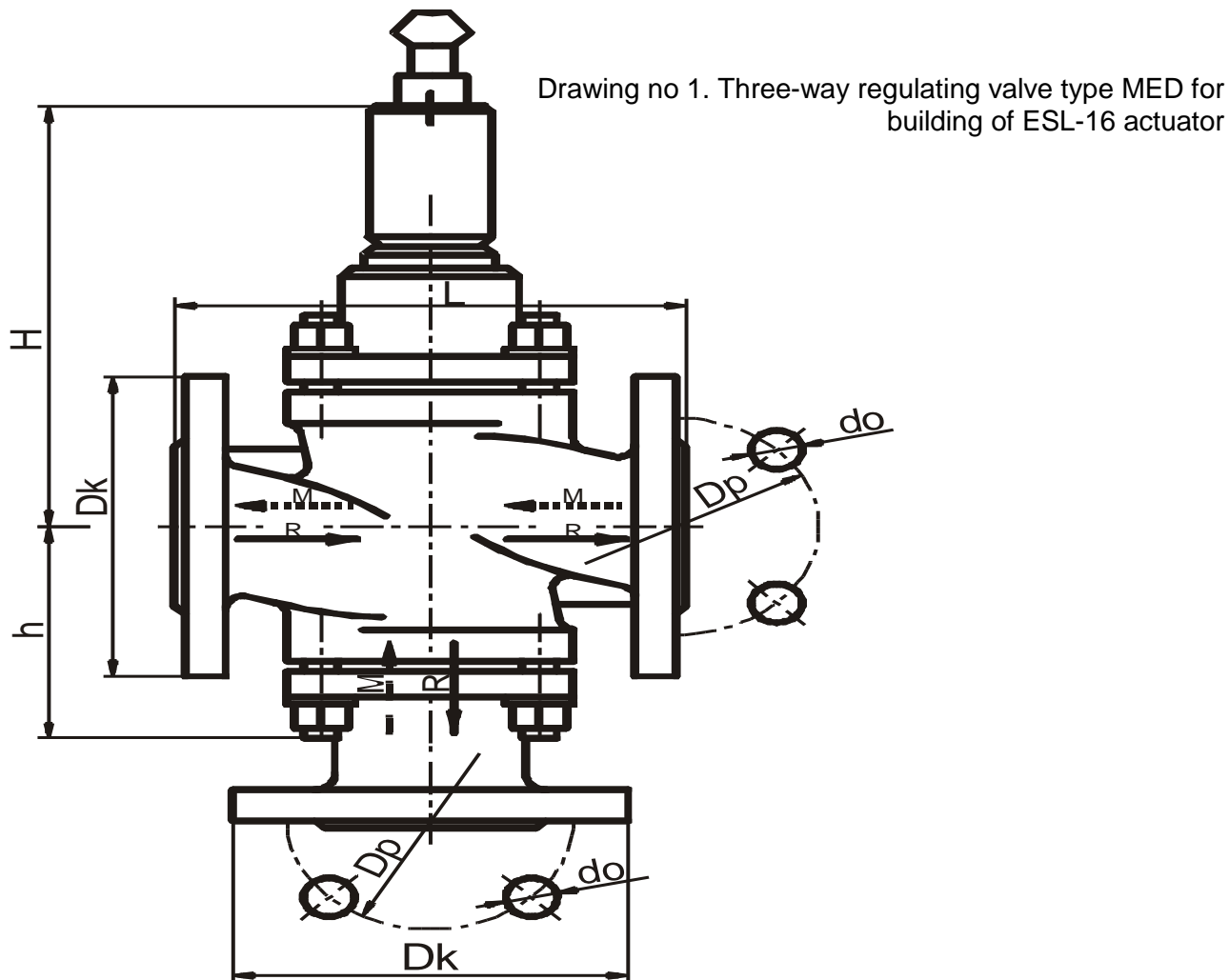

Table no. 3

Valve Type	Dimensions in mm						Valve's travel
	D _p	D _k	d _o	L	H	h	mm
MED-01-11*...12**	65	95	14	130	120	118	3
MED-02-11...12	75	105	14	150	140	129	4
MED-03-11...12	85	115	17	160	145	129	5
MED-04-11...12	100	140	18	180	150	148	6
MED-05-11...12	110	150	18	200	155	148	6
MED-06-11...12	125	165	18	230	205	167	9

 Leakage measured for water at D_p = 0,2MPa * - hard valve seat ** - soft valve seat

 ⇒ - valves at diameter D_n15 and D_n 20 can't be connected with actuator type ESL-16 controlling at three-term signal for 24V or 230V

1.4.3.4. Regulating valve type MEO- and MEZ- for building of ESL-16 actuator

Valve Type	Valve Type							travel
	Dn	Dp	Dk	d _o	L	H	h	mm
MEO-01-11 ^a ...12 ^b MEZ-	15 15	65 65	95 95	14 14	130 130	120 120	118 118	3
MEO-02-11...12 MEZ-02-11...12	20 20	75 75	105 105	14 14	150 150	140 140	129 129	4
MEO-03-11...12 MEZ-03-11...12	25 25	85 85	115 115	17 17	160 160	145 145	129 129	5
MEO-04-11...12 MEZ-04-11...12	32 32	100 100	140 140	18 18	180 180	150 150	148 148	6
MEO-05-11...12 MEZ-05-11...12	40 40	110 110	150 150	18 18	200 200	155 155	148 148	6
MEO-06-11...12 MEZ-06-11...12	50 50	125 125	165 165	18 18	230 230	205 205	167 167	9

Leakage measured for water at Dp = 0,2MPa * - hard valve seat ** - soft valve seat

=) - valves at diameter Dn15 and Dn 20 can't be connected with actuator type ESL-16 controlling at three-term signal for 24V or 230V

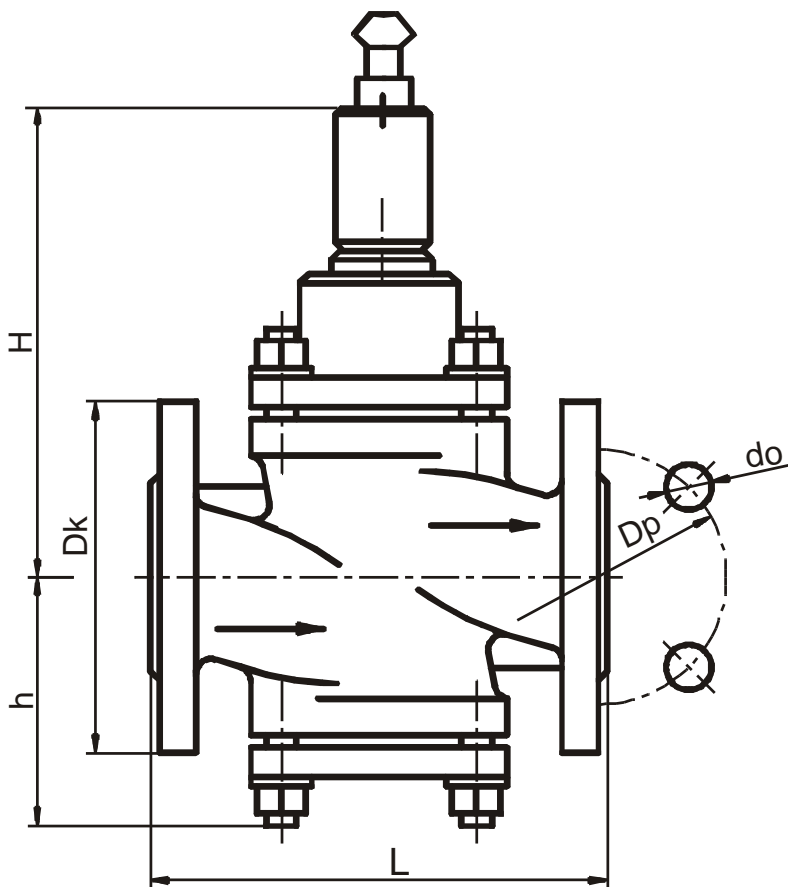

Drawing no. 6. Regulating valve type MEO- and MEZ- for building of ESL-16 actuator

2. TECHNICAL DATA

Nominal pressure 1,6 MPa

Leakage measured for difference pressure 0,2 MPa

Medium temperature at version with hard valve seat max. +250°C

Medium temperature at version with soft valve seat max. +150°C

2.1. THREE-WAY REGULATING VALVES – MIXING TYPE

Table no. 5

Valve type	Dn	Valve travel	Max. permissible pressure before the valve MPa	Max. permissible mixing pressure MPa	Distributed pressure difference MPa	Value kv ± 10% m ³ /h		Max. leakage l/min
						-01	-02	
MED-01-01*÷02**	15	3	1,3	0,6	0,2		3,6	0,30
MED-02-01÷02	20	4	1,3	0,8	0,15		6	0,40
MED-03-01÷02	25	5	1,3	0,8	0,12		10	0,50
MED-04-01÷02	32	6	1,2	0,8	0,08		12	0,63
MED-05-01÷02	40	6	1,2	0,6	0,05		16,5	0,80
MED-06-01÷02	50	9	1,2	0,6	0,05		25	1,0

* - hard valve seat ** - soft valve seat

2.2. REGULATING VALVES – OPENING TYPE

Table no. 6

Valve type	Dn	Valve travel	Max. permissible pressure before the valve MPa	Max. permissible mixing pressure MPa	Distributed pressure difference MPa		Value kv ± 10% m ³ /h
					-01	-02	
MEO-01-01*÷02**	15	3	1,3	1,2		3,6	0,06
MEO-02-01÷02	20	4	1,3	1,3		6	0,08
MEO-03-01÷02	25	5	1,3	0,8		10	0,1
MEO-04-01÷02	32	6	1,2	0,9		12	0,13
MEO-05-01÷02	40	6	1,2	0,6		16,5	0,16
MEO-06-01÷02	50	9	1,0	0,5		25	0,2

* - hard valve seat ** - soft valve seat

2.3. REGULATING VALVES – CLOSING TYPE

Table no. 7

Valve type	Dn	Valve travel	Max. permissible pressure before the valve MPa	Value kv ± 10% m ³ /h		Different pressure Mpa		Max. leakage l/min
				-01	-02	Waer	steam	
MEZ-01-01*÷02**	15	3	1,5		3,6	1,2	1,3	0,06
MEZ-02-01÷02	20	4	1,3		6	1,3	1,3	0,08
MEZ-03-01÷02	25	5	1,5		10	0,8	1,3	0,10
MEZ-04-01:02	32	6	1,2		12	0,9	1,3	0,13
MEZ-05-01÷02	40	6	1,2		16,5	0,6	1,3	0,16
MEZ-06-01÷02	50	9	1,2		25	0,5	1,3	0,20

* - hard valve seat ** - soft valve seat

4. MAINTENANCE INSTRUCTION

4.1 ASSEMBLY INSTRUCTION



Regulating valves might be installed in closed rooms or protected before influence of atmospheric conditions like: rain, snow and others, and rooms, which are free of excessive quantity of aggressive chemical fumes.

The kinds of medium flowing through the valve – liquids or chemical steams must be non-aggressive in relation to grey cast iron and steel 2H13, free from mechanical impurities.

Maximum temperature of medium flowing through the valve + 150 °C.

The pressure and pressure differences of medium flowing through the valve - see the Technical Data.

Working position – arbitrary, vertical is recommended, actuator of the sensor is located under the valve.

Atmospheric requirements – ambient temperature +5 ÷ +50 °C.

Relative humidity: 30 – 80 %.

Necessary protection against direct action of sun radiation, chemical aggressive vapours, water and dust.

Resistance to vibrations – vibrations of frequency 25 Hz and amplitude not greater than 0,1 mm do not have effect on operation.

Valve installation –at the place of valve location one should weld to the pipeline flanges of dimensions, and at distance according to the dimensions given in the dimensioned drawings.

The required additional accessories – one should place in the installation – before and after the regulator valve – two cut-off valves and shunt valve. In addition to that, before the three-way valve one should place the filter with contamination deposit tank.

4.1.1. Valve size selection

The regulating valves are designed for adjusting forces up to 35 kg. In spite of the pressure load for all the valves of rated diameter over 15, one allows exclusively the only one, according to valve size, different value for pressure at the outlet, and maximum pressure difference with closed valve. Both pressure values determine maximum adjusting force.

The first step during the determining of the valve size must be comparison of the stated pressure values with the permissible values (see the technical data).

When selecting the throttling valve (opening and throttling), it unavoidable to match the valve size to the working conditions of the device. When selecting the valve size one should take into account both the pressure conditions and amount of necessary medium flow.

In order to make a good matching, one needs to obtain a regulating valve, which in the whole setting range has got possibly uniform flow increase (or, flow drop) within the limits 0-100% of valve travel.

DIAGRAM

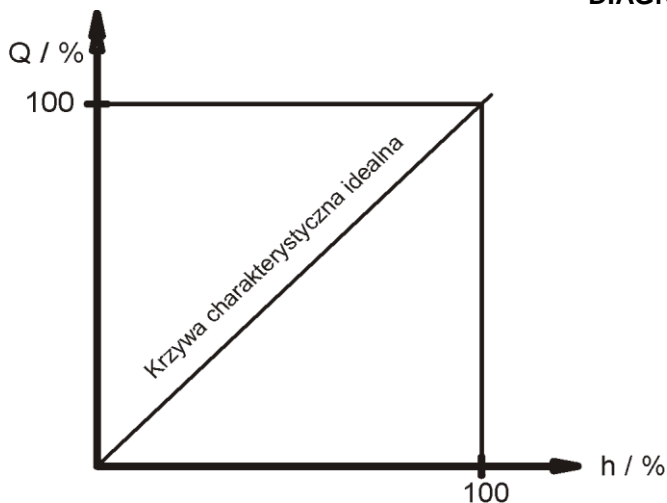

Krzywa charakterystyczna idealna (PL)



Characteristic ideal curve (ENG)

In order to possibly approach the ideal course of characteristic curve, selection of the ratio is of great importance:

$$\frac{\Delta p}{\Delta p_{\max}}$$

Δp - pressure loss with open valve

Δp_{\max} – pressure loss with closed valve, or maximum pressure difference at the valve.

Characteristic curve of the throttling valves has got the course similar to the linear characteristics.

In this way, it is possible to approach the flow characteristic curve to the ideal course only then, if the

quotient $\frac{\Delta p}{\Delta p_{\max}}$ has got the value ca. 0,5 or greater.

DIAGRAM

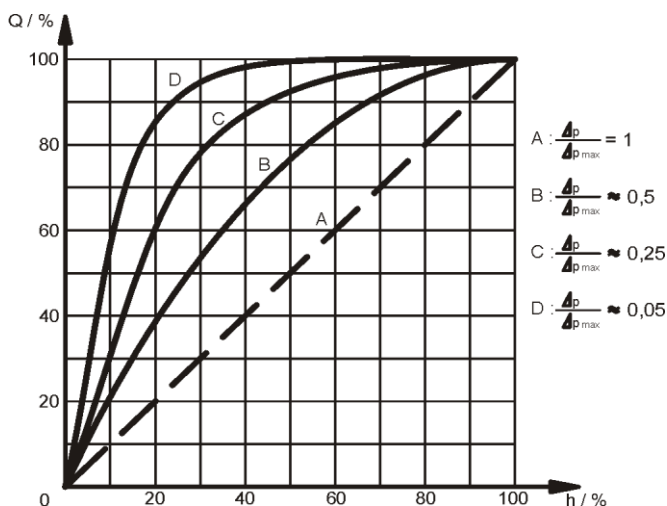

Because incomplete pressure loss of the circuit may only act on the regulating valve, therefore, the value:

$$\frac{\Delta p}{\Delta p_{\max}} = 1 \text{ is practically unavailable}$$



Step 4 – Taking into account the practical aspect, the following guideline is obligatory for the throttling valves:

the throttling valve for operation as the regulating valve is selected well only then, if a part of pressure loss of the fully open valve is at least 30 % out of the possible 50 % of general pressure drop in the circuit of pipe conductors:

$$\Delta p = 0,3 + 0,5 \Delta p_{\max}$$

Valves can be fit only for nominal diameter of pipe.

4.1.2. Examples of good and bad assembly the regulating valve (drawing no. 7)

Examples of installation

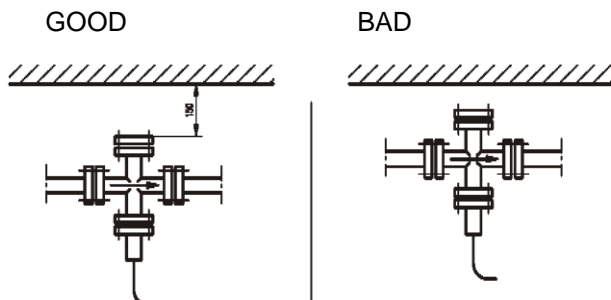

A possibility of taking the filter out must be provided – for cleaning purposes

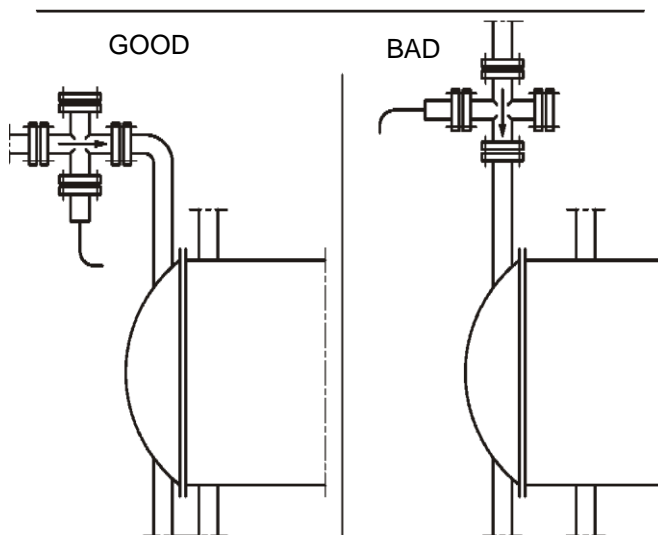

Temperature controllers must be installed horizontally into the feed tube.

	TECHNICAL PRODUCT DOCUMENTATION	ME5-0103
		Page: 15 Pages: 16

4.2. STARTING AND SERVICE INSTRUCTION

4.2.1 Preparing products for starting

Starting. Regulating valves and heating medium have to be opened, shunt valve has to be closed after installation; the installation have to be done acc. to IOM. Chamber of cu-off bellows has to be deaerated.

After starting and getting required parameters the regulating valve will not require further maintenance.

4.2.2 Maintenance instruction

After starting and getting required parameters the regulating valve will not require further maintenance.

4.3 CONSERVATION INSTRUCTION



Regulating valve has to be check very carefully once a year and user has pay attention on technical condition of parts, which are endangered on liquid or live other parts working
After conservation the regulating valve has to be assembled.

4.4 INDUSTRIAL SAFETY INSTRUCTION



Workers who make assembly of regulation valves on objects should have general knowledge of safety instruction and this documentation.

5. STORAGE AND TRANSPORT TERMS

The valves should be stored on shelves, in rooms free from chemical vapours.

Air temperature in the room should vary from +5 ÷ +50°C.

Air relative humidity should be 30 ÷ 80 %.

Dustiness isn't acceptable.

After 6 months storage the sensors have to be checked by made:

- Visual inspection,
- Checking painting and galvanic covers,
- Checking of full complete the unit.

The valves type MEZ – 01 – 03 and MEO – 01 – 03 should be packed in cardboard box, made acc. to drawing ME3-0390. The valves type MEZ – 04 – 06 and MEO – 04 –06 should be packed in cardboard box, made acc. to drawing ME3 – 0407. The transport can be made any transport facilities.

Valves should be transported without shocks and strokes higher up 6+/- 0,5mm at frequency vibrations 2Hz.

	TECHNICAL PRODUCT DOCUMENTATION	ME5-0103
		Page: 16 Pages: 16

6. SETS DELIVERY

The complete shipment of regulation valves includes:

- Technical Product Documentation
- Compatibility Declaration
- Guarantee Card,

7. GUARANTY TERMS

Guaranty terms are determined in guarantee card of Manufacturer – Controlmatica ZAP-PN EFAL Sp. z o.o., Ostrów Wlkp., Poland – guarantee card is added to the each piece of regulating valve.

ATTENTION: The right of introducing design changes in the product, without deteriorating of its operation parameters, is reserved.

8. DECLARATION



CONTROLMATICA ZAP-PNEFAL Sp. z o.o.
ul. Krotoszyńska 35
63-400 Ostrów Wielkopolski
www.controlmatica.com.pl



Ostrów Wielkopolski, 24 październik 2008r.

The original is made in Polish language

Ostrow Wielkopolski, October 24th, 2008

OŚWIADCZENIE PRODUCENTA

Oświadczamy, że wyroby MED, MEO, MEZ spełniają wymagania dyrektywy „Urządzenia Ciśnieniowe” 97/23/WE. Według art. 3 ust. 3 powyższej dyrektywy są wykonane zgodnie z uznaną praktyką inżynierską i nie podlegają oznaczeniu CE.

KIERCOWNIK
SZALU TECHNICZNEGO
mgr inż. Krzysztof Idzior

PREZES ZARZADU
Sebastian Moch

PRODUCER'S DECLARATION

We declare that the products type MEZ –, MEO, MED- meet the requirements of the Directive „Pressure-type Equipment” no. 97/23/WE.

In accordance with art. 3, section 3 of the above mentioned Directive, these goods are made with acknowledged engineering practice and are not subject to the CE marking.

*/-/ Krzysztof Idzior
Manager of Technical
Department*

*/-/ Sebastian Moch
President of the
Board of Directors*

CONTROLMATICA ZAP-PNEFAL Sp. z o.o.
ul. Krotoszyńska 35; PL-63-400 Ostrow Wlkp., Poland
tel.: +48627372250, fax: +48627372724, controlmatica@controlmatica.com.pl
www.controlmatica.com.pl